

- NOTES:
1. RESISTANCE VALUES ARE SHOWN IN OHMS UNLESS OTHERWISE NOTED. (K-KILO OHM, M-MEG OHM)
 2. RESISTOR WATTAGES ARE [1/10W] UNLESS OTHERWISE NOTED.
 3. CAPACITANCE VALUES ARE INDICATED IN MICRO FARADS UNLESS OTHERWISE NOTED. (P-MICRO-MICRO FARAD)
 4. CHIP CAPACITOR'S SIZES ARE (2125) TYPE UNLESS OTHERWISE NOTED.
 5. CAPACITOR ARE RATED 50V UNLESS OTHERWISE NOTED.
 6. RESISTOR TOLERANCES ARE J UNLESS OTHERWISE NOTED.

DESIGN	DRAWN BY	UNIDEN No.	MODEL No.
03.10.18	03.11.19	UB294B	AE77H
KUROKI	KUROKI	TITLE MAIN ASS'Y SCHEMATIC DIAGRAM	
CHECK BY	APPRO. BY	DRAWING No.	
REV. No		UNIDEN CORP.	

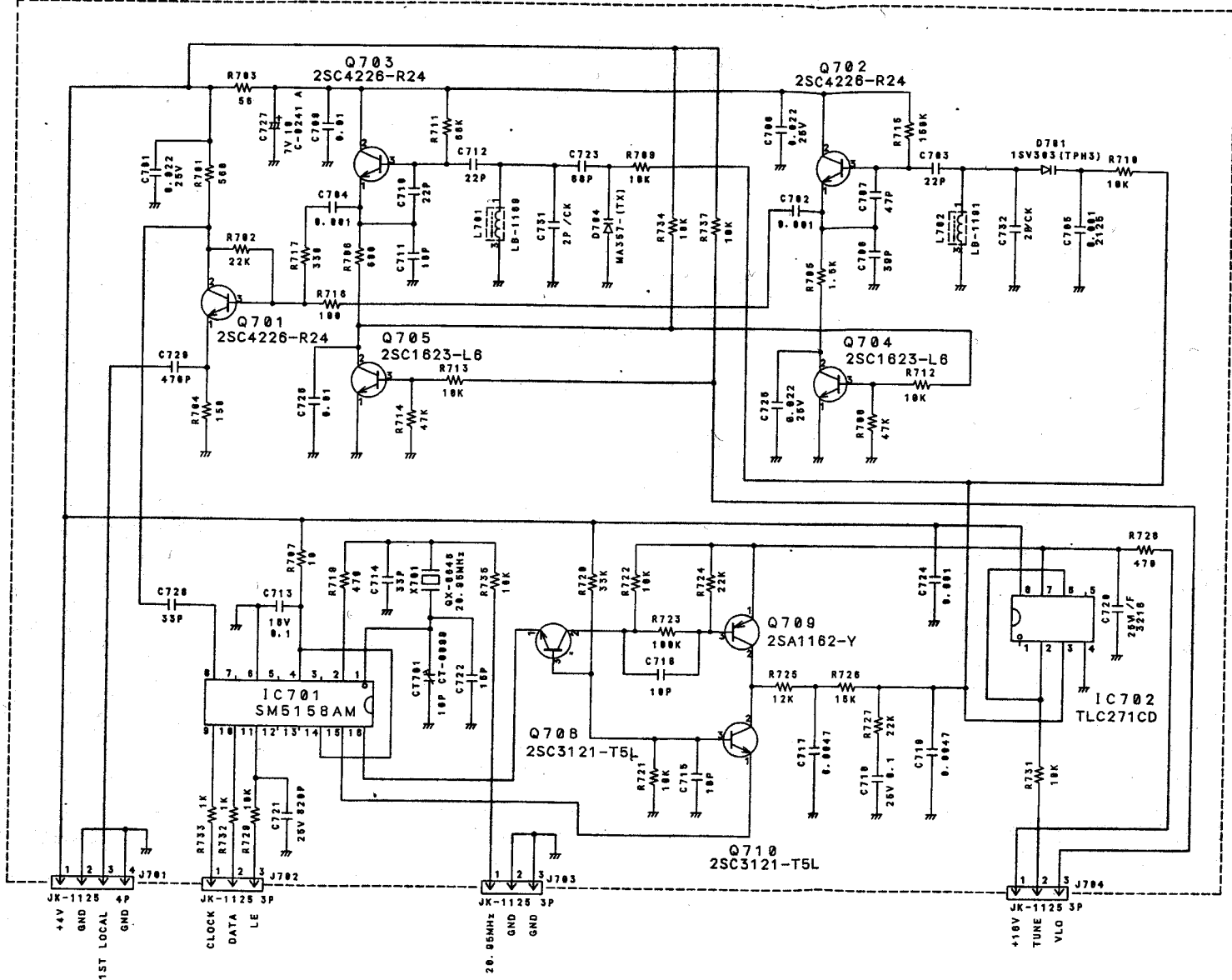

- NOTES:
1. RESISTANCE VALUES ARE SHOWN IN OHMS UNLESS OTHERWISE NOTED. (K=KILO OHM, M=MEG OHM)
 2. RESISTOR WATTAGES ARE [1/18W] UNLESS OTHERWISE NOTED.
 3. CAPACITANCE VALUES ARE INDICATED IN MICRO FARADS UNLESS OTHERWISE NOTED. (P=MICRO-MICRO FARAD)
 4. ALL CAPACITORS TEMPERATURE CHARACTERISTICS ARE [CH] (LESS THAN 1000PF) OR [B] (MORE THAN 1000PF) UNLESS OTHERWISE NOTED.
 5. CHIP PARTS ARE NOT SPECIFIED IN THIS DRAWING PLEASE REFER TO THE PARTS LIST FOR THE CHIP PARTS.
 6. CHIP CAPACITORS SIZE ARE [1808] UNLESS OTHERWISE NOTED.
 7. RESISTOR TOLERANCES ARE J UNLESS OTHERWISE NOTED.

DESIGN	DRAWN BY	UNIDEN No.	MODEL No.
'83.10.30	'83.10.30	UB294B	AE77H
KUROKI	KUROKI	TITLE PLL ASS'Y	
CHECK BY	APPRO. BY	SCHEMATIC DIAGRAM	
		DRAWING No.	
REV. No.		UNIDEN CORP.	

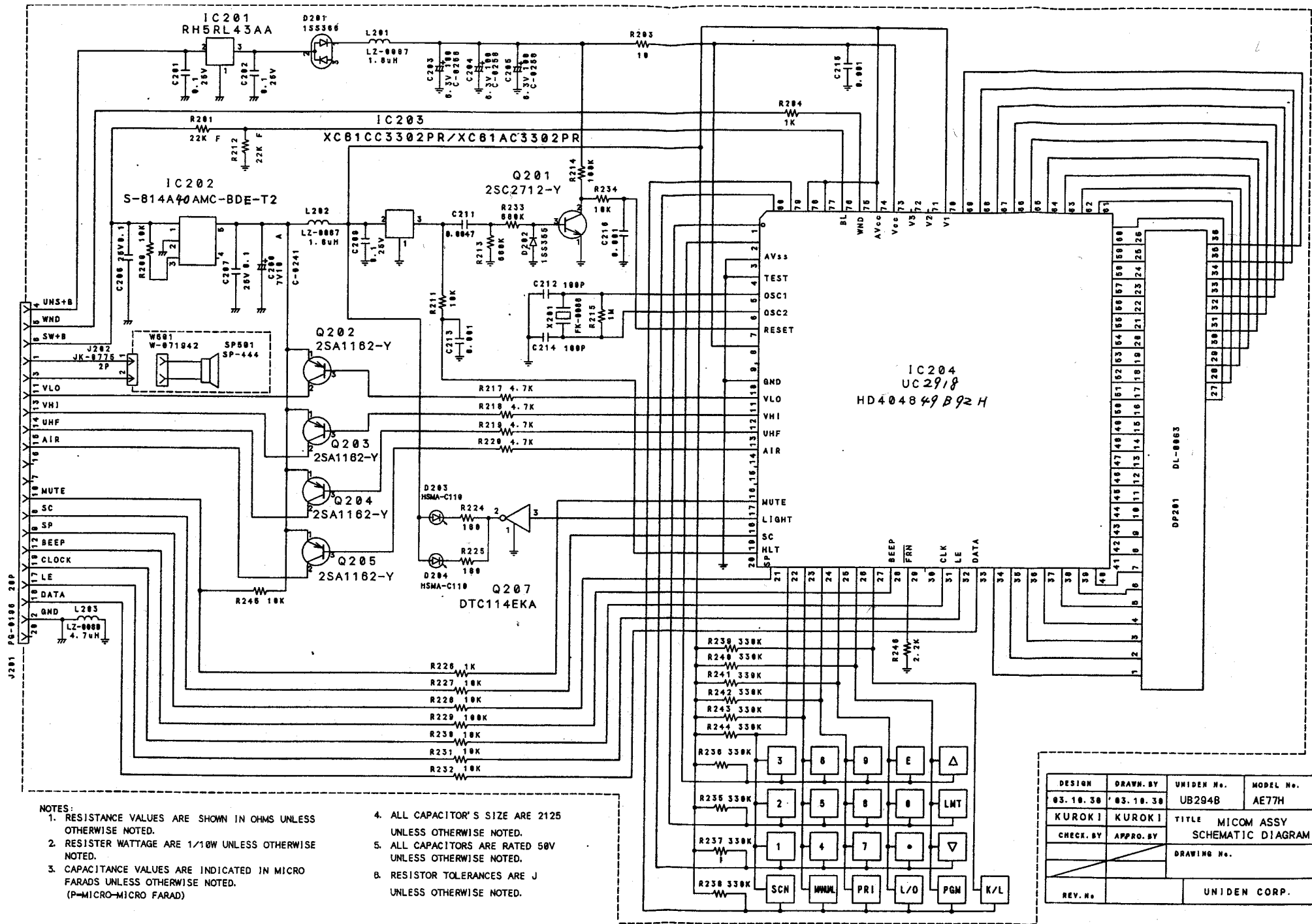

- NOTES:
1. RESISTANCE VALUES ARE SHOWN IN OHMS UNLESS OTHERWISE NOTED.
 2. RESISTOR WATTAGE ARE 1/10W UNLESS OTHERWISE NOTED.
 3. CAPACITANCE VALUES ARE INDICATED IN MICRO FARADS UNLESS OTHERWISE NOTED. (P-MICRO-MICRO FARAD)
 4. ALL CAPACITOR'S SIZE ARE 2125 UNLESS OTHERWISE NOTED.
 5. ALL CAPACITORS ARE RATED 50V UNLESS OTHERWISE NOTED.
 6. RESISTOR TOLERANCES ARE J UNLESS OTHERWISE NOTED.

DESIGN	DRAWN BY	UNIDEN No.	MODEL No.
03.10.30	03.10.30	UB294B	AE77H
KUROKI	KUROKI	TITLE	MICOM ASSY
CHECK BY	APPROV BY		SCHEMATIC DIAGRAM
		DRAWING No.	
REV. No.		UNIDEN CORP.	

Frequency Ranges AE 77 H

Frequency Range (MHz)	Steps (kHz)	Mode	Application
66– 88	5	FM	4 m Band, VHF-low range for public utilities
108.0000-136.9916	12.5 / 8.33	AM	International Air Band
137.0000-143.9950	5	FM	Weather satellites and military mobile radio
144-145.9875	12.5	FM	2 m Amateur Radio
146.000-174 MHz	5	FM	VHF Hi Band, Commercial Land Mobile Radio, Taxis, Marine Radio, Public Utilities
406.0000-512 MHz	12.5	FM	UHF PMR Band for Commercial Mobile Radio, 70 cm Amateur Radio, Police and Public Utilities

Factory Programmed Search Ranges

Display	MHz	Application
b1	84.0150 -87.2550	Police, Rescue and Fire Brigade (Germany only)
b2	108.0000-137.9916	Air band
b3	137.0000-143.9950	Weather satellites and military mobile radio
b4	144.0125-145.9875	2 m Amateur Radio
b5	146.0100-155.9900	VHF Hi Band, Commercial Land Mobile Radio, Taxis, Marine Radio, Public Utilities
b6	156.0250- 157.4250	Marine Radio, Ship- and Coastal Stations Simplex Band
b7	160.6250-162.0250	Marine Radio, Harbour Radio Traffic, Coastal Stations, Locks and Weather Forecasts (upper duplex channels)
b8	162.0300- 173.9900	upper part of VHF Land Mobile Radio
b9	430.0125-439.9875	70 cm Amateur Radio
b10	450.0000-469.9875	UHF Commercial PMR, Railways

Frequency Ranges AE 77 H

Frequency Range (MHz)	Steps (kHz)	Mode	Application
66– 88	5	FM	4 m Band, VHF-low range for public utilities
108.0000-136.9916	12.5 / 8.33	AM	International Air Band
137.0000-143.9950	5	FM	Weather satellites and military mobile radio
144-145.9875	12.5	FM	2 m Amateur Radio
146.000-174 MHz	5	FM	VHF Hi Band, Commercial Land Mobile Radio, Taxis, Marine Radio, Public Utilities
406.0000-512 MHz	12.5	FM	UHF PMR Band for Commercial Mobile Radio, 70 cm Amateur Radio, Police and Public Utilities

Factory Programmed Search Ranges

Display	MHz	Application
b1	84.0150 -87.2550	Police, Rescue and Fire Brigade (Germany only)
b2	108.0000-137.9916	Air band
b3	137.0000-143.9950	Weather satellites and military mobile radio
b4	144.0125-145.9875	2 m Amateur Radio
b5	146.0100-155.9900	VHF Hi Band, Commercial Land Mobile Radio, Taxis, Marine Radio, Public Utilities
b6	156.0250- 157.4250	Marine Radio, Ship- and Coastal Stations Simplex Band
b7	160.6250-162.0250	Marine Radio, Harbour Radio Traffic, Coastal Stations, Locks and Weather Forecasts (upper duplex channels)
b8	162.0300- 173.9900	upper part of VHF Land Mobile Radio
b9	430.0125-439.9875	70 cm Amateur Radio
b10	450.0000-469.9875	UHF Commercial PMR, Railways